



ACE School 2008

IP Evolution Next Generation IP Switching

Thomas B. Fulton, P.E.
Fulton Engineering, Inc.
(303) 410-6616



NGN/Softswitch/IMS ??

- Softswitch = Next Generation Network
 - “All IP”
 - Standardization efforts limited
 - Typically refers to a product or suite of products
- IMS = IP Multimedia Subsystems
 - Extension of NGN, Includes Softswitch
 - Standardized (3GPP, ITU, IETF, ETSI, CableLabs)
 - Typically defines an architecture/concept
(not a product or specific combination)
- Standards complex, continuing to evolve...

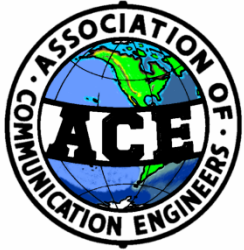

NGN Switch is Core of IMS

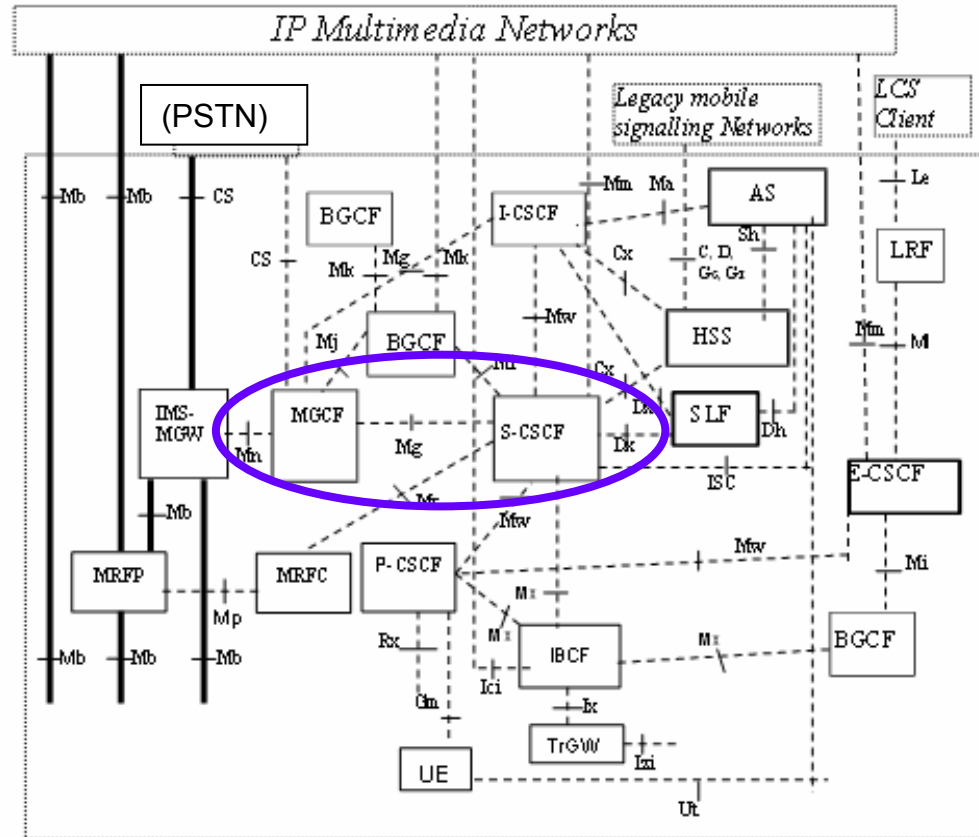



IP Evolution

- Forward View for Rural Telcos
 - New Terminology
 - New Ways of thinking
 - New Architecture
 - New Access Technology
 - New Transport Technology



IP Evolution

- Reality Viewpoint
 - Long Term Support for:
 - Loop switched copper fed POTS
 - T1 Based ISUP (or MF) trunks
 - TDM for Long Distance
 - TDM for Intercarrier, 911
 - Regulatory Requirements slow to change



Evolution Path

- TDM \Rightarrow IP
- 64 Kbps DS0 \Rightarrow SIP
(Session Initiation Protocol)
- Circuit Switched \Rightarrow Packet Switched

**Where does voice become digital?
Where does voice become IP?**



Standards for Voice

- *TDM – ANSI T1 series, esp. T1.107*
 - *64 Kbps voice DS0s, T1 circuits, DS3s*
- H.323 (ITU)
 - “telco like” formalized protocol
- SIP - Session Initiation Protocol
RFC 3261 (IETF)
 - “internet like” simpler definitions



Interswitch Transport

- *TDM (ANSI T1 series) voice & signaling*
- H.323 (protocols for audio/visual communications)
- MEGACO (Media Gateway and Control)
- MGCP (Media Gateway Control Protocol)
- SS7 ⇨ SIGTRAN



Typical Switch Architecture

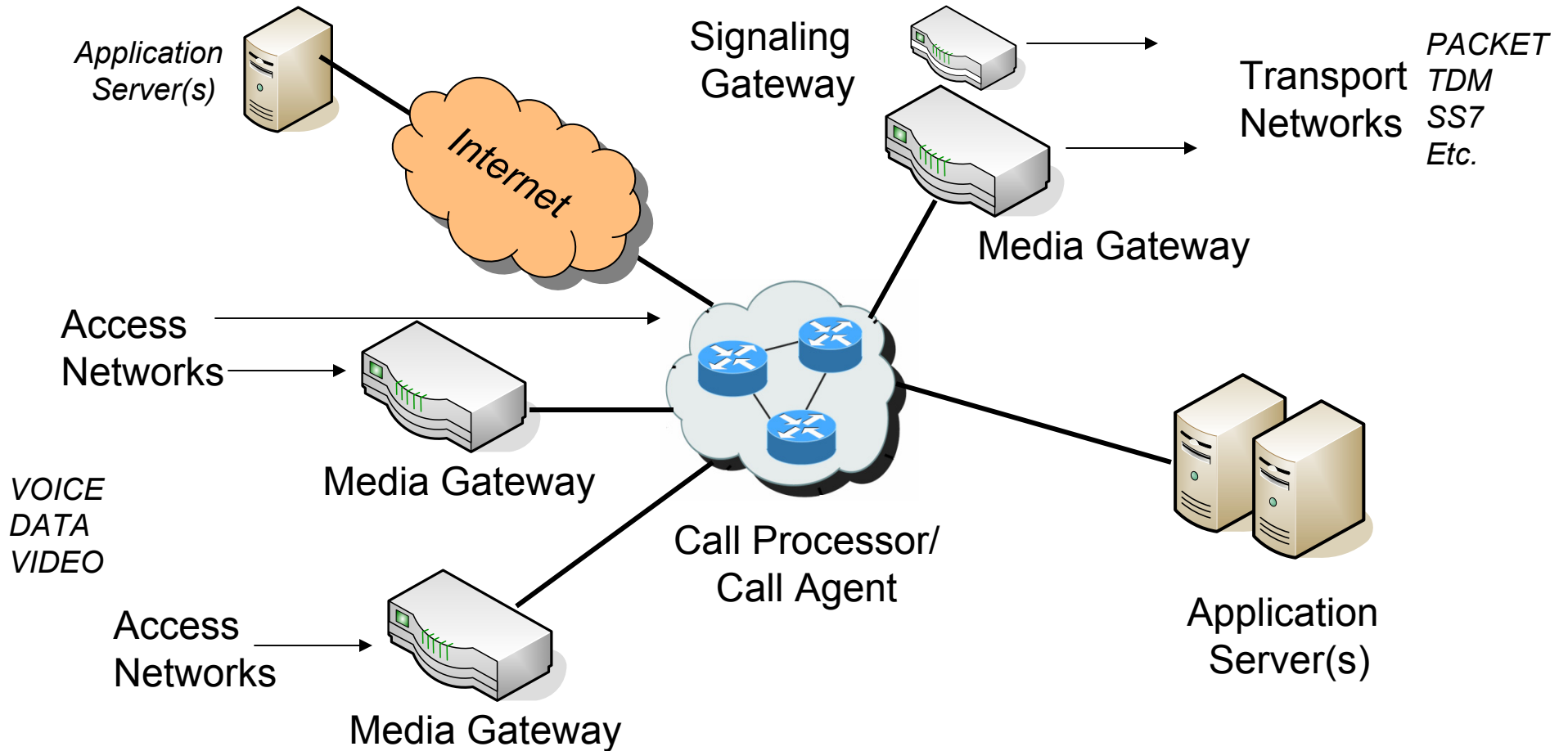



Collapsed Architecture ?

- Today: 1 switch per exchange
Rural Telco Model
 - Replace remotes with Stand-alone DLCs or small softswitch subsets
 - IP Backhaul to Central Office
- Future: 1 switch per company or consortium
“Wireless” model (1 switch per state?)



Benefits/Disincentives

- Centralize critical functions
 - Expertise (switch engr, technicians)
 - Maintenance (one location/facility)
 - Interconnections
- Impact to Regulatory / Financial ?
 - First Point of switching / point of interconnection
 - Settlements / intercarrier compensation
- Impact to Customer
 - Reliability / performance



Combined Voice/Data

- “Convergence”
 - One network instead of 2 or 3
 - Centralized expertise/maint/interconnection
 - Blend or merge telephony and IT resources
 - Enables local VoIP services



Softswitch / NGN Architecture

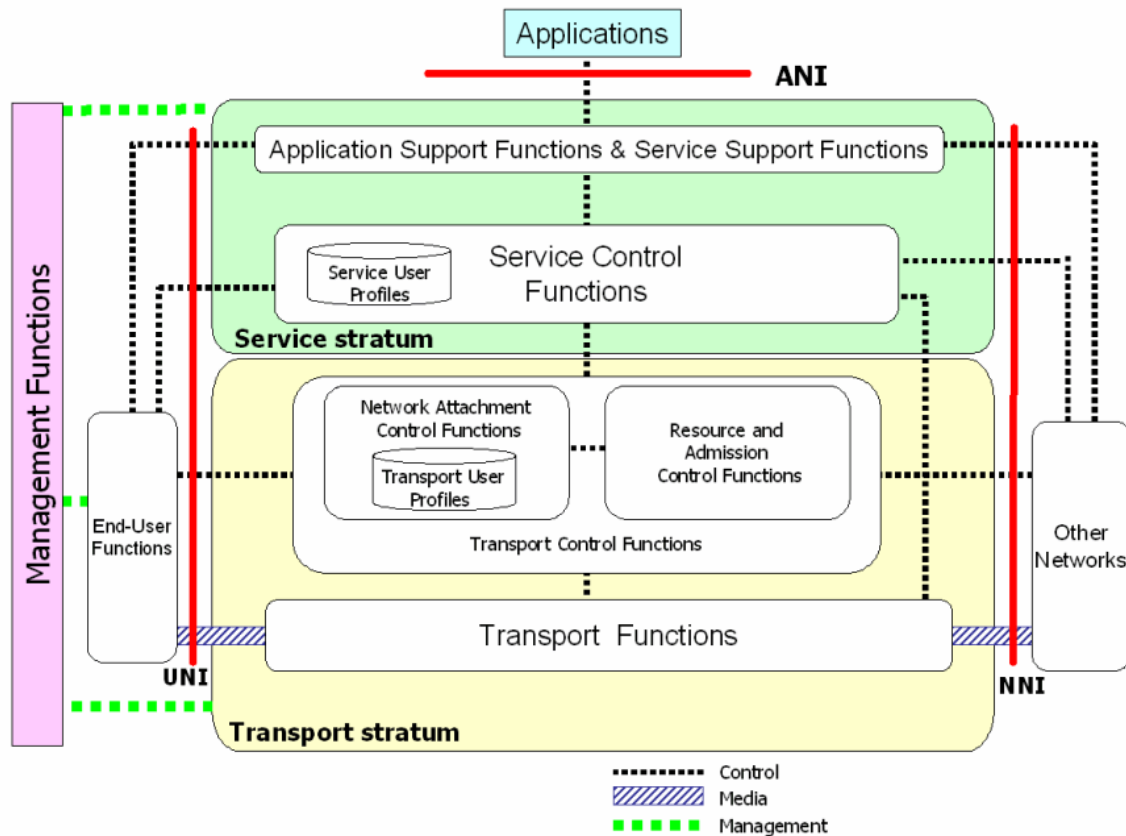



Key Elements of Switching

Application
Servers

Call
Agents

Media
Gateways



Call Agent

- Performs core switching
- Packet switching
- High reliability, high Quality of Service
- Acts on instructions from Application Servers
- Controls trunking gateways & access network feeds



Media Gateway

- Provides interface to non-packet media
- Performs protocol conversion
- Terminates access networks
 - Ethernet backhaul, GR303, POTS, wireless
- Interconnect transport providers
 - Ethernet, T1, SONET
- Interconnect signaling networks
 - SS7 / SIGTRAN



Application Servers

- Enhanced functionality
 - Voice mail / Unified messaging
 - 800 number look-ups
 - Local Number Portability look ups
 - Conference calling
- Flexible, programmable
 - May have long-term 'core' applications or
 - Short term 'popular' applications



Applications

- Consider Facebook
 - Open source application protocol released Spring 2007
 - In 8 months, 20,000 applications developed and deployed by users
 - Social Networking concepts very different
 - Mostly fun; light hearted; short-hand msgng
 - Often simple conversational – “did you know...”
 - Users drive demand/usage
 - Vast marketing potential (ads on phones?)



Impact to Telco

- Competition is deploying softswitch
- Retention of old iron will be costly
 - Adding new services / new technologies
 - Maintaining multiple customer systems
 - Obtaining support from vendor
- All IP architecture is here today



Next Steps

- Education
 - Switch engineers / technicians
 - IT personnel
 - Managers
- Examine options
 - Existing architecture
 - Competitive landscape
 - Vendor offerings



Next Steps, Con't

- Develop Requirements
- May be cap & grow, augmentation, total system replacement or other strategy
- Gather Vendor specifics / Q&A
- Plans & Specifications
- Bid – Procurement – Contract
- Installation, test, turn-up